

TD-IT IT-TYPE 拱型橡胶护舷

特点：

- 1、设计压缩变形为57.5%，吸能量与超级拱型(TD-B)护舷相比，约提高10%左右；
- 2、安装尺度小，TD-B500H与 TD-IT500H 相比，安装螺栓中心距从840mm 降为600mm，适应范围广；
- 3、可以竖向、横向或混合布置，设计灵活；
- 4、前部设置防冲板，护舷面压力可根据要求设计。

规格：

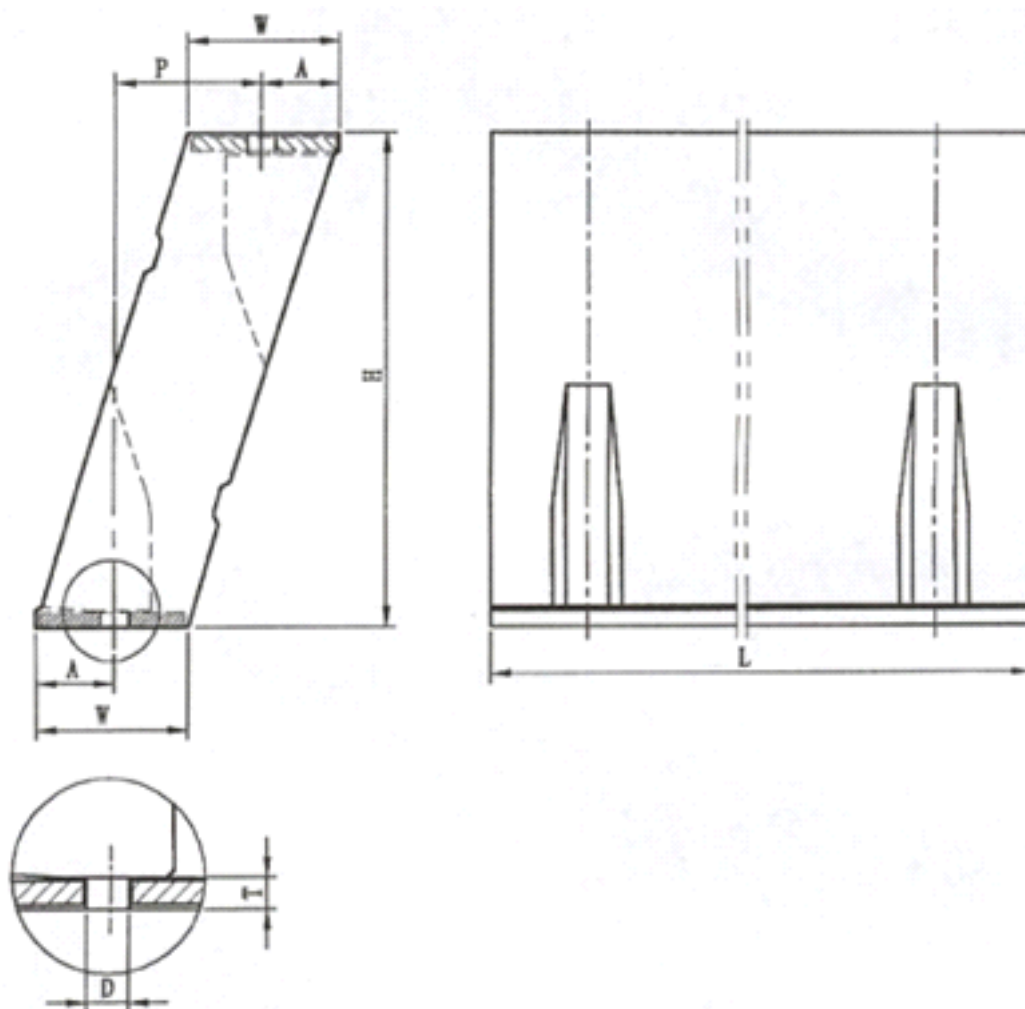

尺寸Size 规格 Specification	H	W	P	A	D	T
TD-IT500H	500	158	142	87	36	20
TD-IT600H	600	188	200	87	36	20
TD-IT750H	750	235	230	118	43	26
TD-IT800H	800	250	240	129	43	26
TD-IT1000H	1000	322	310	162	50	31
TD-IT1250H	1250	400	390	196	56	36
TD-IT1450H	1450	454	454	228	56	41
TD-IT1600H	1600	500	480	257	64	50

性能:

长度: 1000mm

配方Compounds	高反力型High reaction force (P1)		标准反力型Standard reaction force (P0)	
性能 规格 Specification	反力 Reaction force (KN)	吸能量 Energy absorption (KN·M)	反力 Reaction force (KN)	吸能量 Energy absorption (KN·M)
TD-IT500H	265	61	186	43
TD-IT600H	320	88	224	62
TD-IT750H	401	137	281	96
TD-IT800H	428	157	299	110
TD-IT1000H	534	245	374	172
TD-IT1250H	667	383	467	268
TD-IT1450H	775	516	543	361
TD-IT1600H	854	628	598	440

注: 设计压缩变形: 57.5% Note: Rated deflection 57.5%
 性能公差: ±10% Performance tolerance ±10% of rated
 其它长度的性能值为1000mm的性能值乘以长度比(即性能和长度成正比)。

配件:

1. 码头联接件

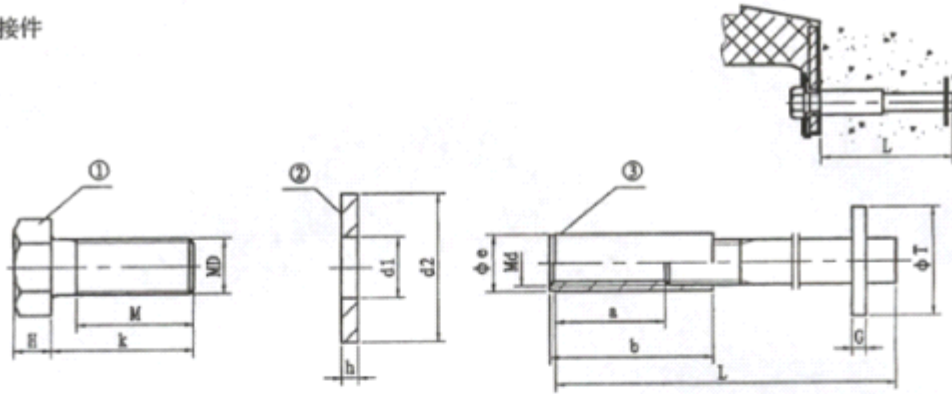

名称 Description 尺寸Size 规格Specification	①螺栓Bolt				②垫片Spacer			③预埋螺母Anchor nut						
	D	k	M	H	d2	d1	h	d	e	a	b	L	G	T
TD-IT500H	30	85	70	19	56	33	4	30	42	75	120	360	10	80
TD-IT600H	30	85	70	19	56	33	4	30	42	75	120	360	10	80
TD-IT750H	36	90	75	23	66	39	5	36	44	85	125	440	12	90
TD-IT800H	36	90	75	23	66	39	5	36	44	85	125	440	12	90
TD-IT1000H	42	100	80	26	78	45	6	42	60	85	130	500	12	100
TD-IT1250H	48	120	95	30	92	52	8	48	65	100	150	570	12	110
TD-IT1450H	48	120	95	30	92	52	8	48	65	100	150	570	12	115
TD-IT1600H	56	135	110	35	105	62	10	56	71	105	165	620	16	120

2. 防冲板联接件

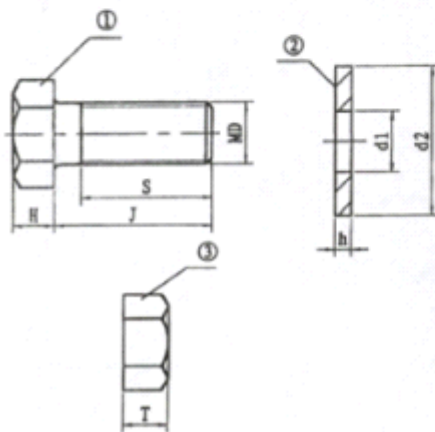

名称 Description 尺寸Size 规格Specification	①螺栓Bolt				②垫片Spacer ③螺母nut			
	D	J	S	H	d1	d2	h	T
TD-IT500H	30	90	45	19	33	56	4	24
TD-IT600H	30	90	45	19	33	56	4	24
TD-IT750H	36	110	50	23	39	66	5	28
TD-IT800H	36	110	60	23	39	66	5	28
TD-IT1000H	42	125	65	26	45	78	6	34
TD-IT1250H	48	135	80	30	52	92	8	34
TD-IT1450H	48	135	80	30	52	92	8	38
TD-IT1600H	56	160	90	35	62	105	10	45